

2 Tonne HL Reach Truck





Capacity

At 600 mm load centre:
Model GRT 200E - 2000 kg

Standard Equipment

- Integral side shifting carriage reduces head length to give superior deration characteristics
- 3-phase AC motors for traction, hydraulics and steering guarantee high energy efficiency and maintenance-free operation
- Independent electronic controllers for traction, hydraulics and steering are integrated by CAN-Bus technology resulting in synchronized equipment control with high level of safety
- Speed-sensitive electric steering automatically slows the truck down to safe limits while turning
- Programmable turning ratio gives the operator superior control over truck maneuverability
- Ergonomic suspension seat, automotive style accelerator & brake pedals, and adjustable steering wheel ensure high level of operator comfort over long working hours
- Fingertip control for all hydraulic functions and travel direction is integrated for one-hand operation. This allows the operator to focus on handling the load
- Hydraulic rear wheel brakes assisted by electromagnetic and regenerative braking of drive wheel ensures precise control and stability
- Parking brake is electromagnetic and automatically operates when operator lifts the foot off the dead man's pedal
- Vulkollan load wheels and drive tyre give superior traction control with a higher tolerance to surface irregularities
- Clear view overhead guard offers better visibility of the load at heights

Battery

- Battery can be pulled out of the chassis with the reach carriage to be lifted off or rolled out to one side (optional)
- 48V traction battery, offered in 540 and 700Ah capabilities to ensure optimum matching with different performance cycles, derated capacities and lift heights

Mast

- 3 stage full free lift mast with enhanced visibility ISO class 2A forks
- Unique nesting of mast sections with tight running clearances guarantees a robust and stable load handling system
- Hose burst valve prevents sudden lowering of load in case of hose failure





Dimensions

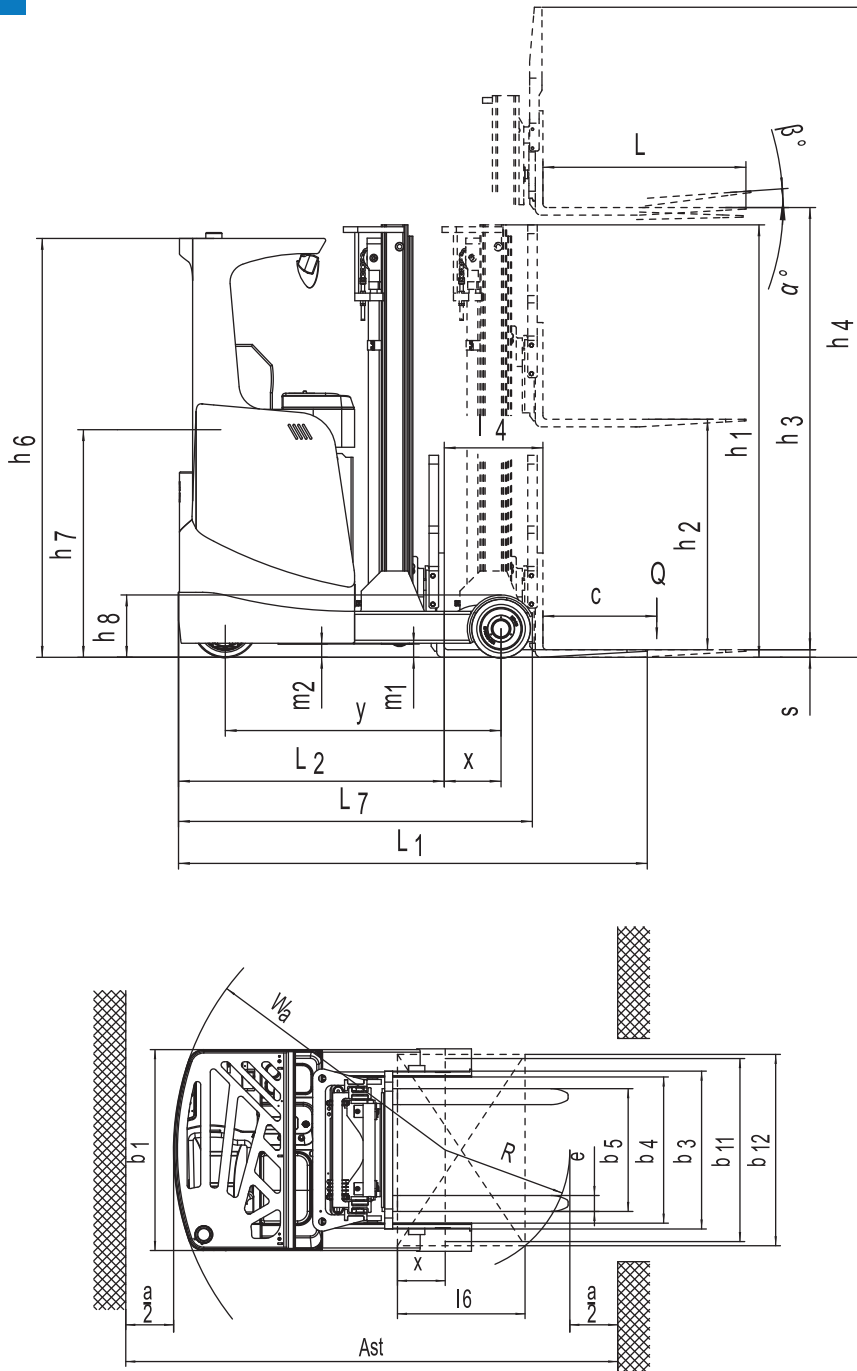

Standard Offerings

1. Rack height selection
2. Work light
3. Travel alarm
4. Flashing light
5. Rear view mirror
6. Tool kit

Performance Enhancing Options

1. Camera system with colour monitor
2. Freezer conditioning up to (-25°C)
3. Battery compartment rollers



Electric Reach Truck 2T - GRT 200E

Specifications

Characteristics				
1.1	Manufacturer			Godrej
1.2	Model designation			GRT 200E
1.3	Drive unit			Battery
1.4	Operator type			Seated
1.5	Rated capacity	Q	t	2
1.6	Load centre distance	c	mm	600
1.9	Wheelbase	y	mm	Refer Table 2
Weights				
2.1	Service weight (include battery)		kg	Refer Table 2
2.2	Axle loading, fork advanced, unladen driving side/loading side (base configuration)		kg	1700/1310
2.3	Axle loading, fork retracted, unladen driving side/loading side (base configuration)		kg	1990/1020
2.4	Axle loading, fork advanced, laden driving side/loading side (base configuration)		kg	820/3820
2.5	Axle loading, fork retracted, laden driving side/loading side (base configuration)		kg	1640/3000
Wheels Chassis				
3.1	Tyre type driving wheels/loading wheel			Polyurethane
3.2	Tyre size, driving wheels (diameter x width)		mm	343 x 140
3.3	Tyre size, loading wheels (diameter x width)		mm	310 x 208
3.4	Tyre size, caster wheels (diameter x width)		mm	102 x 51
3.5	Wheels, number driving, caster/loading (x = drive wheels)			1 x 2/2
3.6	Track width, front, driving wheels		mm	0
3.7	Track width, rear, loading wheels		mm	1238
Dimensions				
4.1	Tilt of mast/fork carriage forward/backward	α / β	°	2/4
4.2	Height, mast lowered	h_1	mm	Refer Table 2
4.3	Free lift (load backrest)	h_2	mm	120
4.4	Lift height	h_3	mm	Refer Table 1
4.5	Height, mast extended	h_4	mm	Refer Table 1
4.7	Height of overhead guard (cabin)	h_6	mm	2210
4.8	Seat height/standing height	h_7	mm	1200
4.10	Height of wheel arms	h_8	mm	330
4.19	Overall length (minimum)	l_1	mm	Refer Table 2
4.20	Length to face of forks	i_2	mm	Refer Table 2
4.21	Overall width	b_1 / b_2	mm	1260/1270
4.22	Fork dimensions	$s / e / l$	mm	40 x 120 x 1070
4.23	Fork carriage class/type A, B			A
4.24	Fork carriage width	b_3	mm	990
4.25	Distance between fork-arms	b_5	mm	240/740
4.26	Distance between wheel arms/loading surfaces	b_4	mm	915
4.28	Reach distance	i_4	mm	Refer Table 2
4.31	Ground clearance, laden below mast	m_1	mm	70
4.32	Ground clearance, centre of wheelbase	m_2	mm	70
4.34.1	Aisle width for pallets 1000 x 1200 crossways	A_{st}	mm	Refer Table 2
4.34.2	Aisle width for pallets 800 x 1200 crossways	A_{st}	mm	Refer Table 2
4.35	Turning radius	W_a	mm	Refer Table 2
4.37	Length across wheel arms (exclusive fork)	l_7	mm	Refer Table 2
Performance				
5.1	Travel speed, laden/unladen		Km/h	9/9.5
5.2	Lifting speed, laden/unladen		m/s	0.28/0.42
5.3	Lowering speed, laden/unladen		m/s	0.3/0.33
5.4	Reaching speed, laden/unladen		m/s	0.9/0.9
5.8	Max. gradeability, laden/unladen		%	10/15
5.10	Service brake type			Hydraulic
	Park brake type			Electromagnetic
Drive				
6.1	Drive motor rating S2 60 min		kW	6.4
6.2	Lift motor rating at S3 15%		kW	13
6.3	The maximum allowed battery size		mm	1220 x 427 x 778
6.4	Battery voltage/nominal capacity K5		V/Ah	48V/700Ah
6.5	Battery weight		kg	900/1150
Other				
8.1	Type of drive unit			AC
10.5	Steering type			Electronic
10.7	Sound pressure level at the driver's ear		dB (A)	75

All dimensions and specifications are subject to variations within $\pm 15\%$

1. The parameters in the table are of the standard model. For more information please contact us.
2. The parameters are subject to change without notice.



Table 1: Mast Specifications

Model Description	Mast Type	Base Load Capacity (kg) @ 600 mm Load Centre	MFH h3 (mm)	OAHL h1 (mm)	OAHR h4' (mm)	Free Lift h2' (mm)	Derated Capacity (kg) at MFH @ 600 mm Load Centre	Standard Battery Capacity (48 V)	Service Weight (including battery) kg
GRT200E-110	3 STAGE CVM	2000	11000	4490	12065	3425	800	700 Ah	4940
GRT200E-120	3 STAGE CVM	2000	12000	4820	13065	3755	600	700 Ah	4990

All dimensions and specifications are subject to variations within ± 15% *h2 and h4 with load back rest

Table 2: Dimensions (mm)

With Side Shift	GRT200E	
Mast style		3-stage mast
Lift height (h ₃)		11m ≤ h ₃ ≤ 12m
Wheelbase	y	1594
Overall length (minimum)	l ₁	2577
Length to face of forks	l ₂	1507
Reach distance	l ₄	555
Aisle width for pallets 800 mm W x 1000 mm L	Ast	2820
Aisle width for pallets 1000 mm W x 1000 mm L	Ast	2879
Aisle width for pallets 1000 mm W x 1200 mm L	Ast	3041
Aisle width for pallets 1200 mm W x 1000 mm L	Ast	2937
Aisle width for pallets 1200 mm (W) x 1200 mm L	Ast	3098
Turning radius	W _a	1840
Length across wheel arms (exclusive of fork)	l ₇	2005



COMFORTABLE LEGROOM



EASE OF SERVICE ACCESSIBILITY



Our Range



3-wheel Electric Forklifts
0.8 to 1.6 tonne



Electric Forklifts
1 to 5 tonne



Diesel Forklifts
1.5 to 4 tonne



Diesel Forklifts
5 to 10 tonne



Diesel Forklifts
12 to 25 tonne



Dock Leveler
9 and 12 tonne



Hand Pallet Truck
2.5 tonne



Powered Pallet Truck
1.5 and 2 tonne



Electric Stacker
1.2 and 1.5 tonne



Articulated Forklifts
1.2 to 2 tonne



Platform Truck
2, 3, and 4 tonne



Tow Truck
2, 5 and 6 tonne
(Stand up & sit down model)



CROWN
Warehousing
Equipment



KOMATSU
Forklifts



TENNANT
Industrial Cleaning
Equipment



HUBTEX
Side Loaders



MERLO



IMER

DISTRIBUTION: Our network of 17 company owned branches brings us closer to customers across India. This also gives us the edge to distribute equipment from global giants including Crown, Komatsu, Merlo, Tennant, Hubtex and Imer in India.

GODREJ & BOYCE MFG. CO. LTD.

Plant 16, Pirojshanagar, Vikhroli, Mumbai 400079.
• Tel: +91 22 6796 4660/ 73 • Fax: +91 22 6796 1519
• E-mail: mhemktg@godrej.com • URL: http://godrejmh.in

Overseas Branch and Service Centre

SAIF Zone, R.O. Box 8549, Sharjah, U.A.E.
• Tel: +971 55 8992305/ 2316 • Mob: 00 971 504629701
• Fax: 00 971 65570966 • E-mail: mahesh@godrej.ae

Branches & Service Centres

- Mumbai: 022 67961725 / 67961291
- Pune: 020 66255121-22
- Ahmedabad: 079 66060646 / 66060701 / 66060606
- Indore: 0731 4069335/ 2532917
- Chennai: 044 66544431-32
- Bangalore: 080 66472251
- Kochi: 0484 6612777/ 6612609
- Hyderabad: 040 66431203
- Vizag: 0891 2517930 / 2746511-2-3

- Delhi: 011 66507340/ 50
- Chandigarh: 0172 5012525 / 5037738
- Jaipur: 0141 6701441/ 2
- Lucknow: 0522 6754961
- Kolkata: 033 66013771-75
- Bhubaneshwar: 0674 2374626
- Coimbatore: 0422 2545799/ 599
- Guwahati: 03612 468242
- Raipur: 07716606706

To find out more about what's new at Godrej Material Handling, check out www.godrejmh.in

