

CROWN

PTH 50 SERIES



Built and Backed to Last

The PTH 50 Series may be the smallest truck in the Crown product family, but it can make a big difference for your operation with excellent ergonomics, application versatility and long-term durability. With a 3-year warranty covering pump assembly, frame, handle, lift linkage and pushrod weldments, its built to last and backed to prove it.

The Crown PTH 50 Series.
Exceptional Long-Term Value



Visit crown.com

See the PTH 50 Series



The Must-Have Hand Pallet Truck

Find power in productivity with the PTH 50 Series. It's built to last and easy to use in any part of your facility. That's why Crown's pallet truck is the go-to truck in most any application.

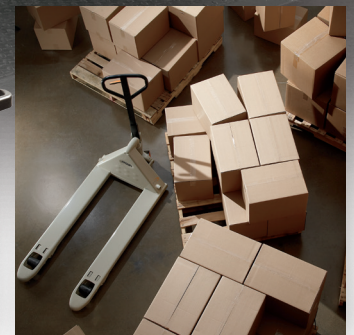

Durability

Complete the tough challenges and benefit from simpler service with an intuitive design and dependable, long-lasting components.

Ease Of Use

Feel the difference of excellent maneuverability and operator-friendly functionality as you comfortably move from task to task throughout your facility.

Versatility

Don't settle for less. The PTH 50 Series can be customized in a number of ways to meet your unique needs.

Peace of Mind

Built to last and warranted to prove it, the PTH 50 Series includes an industry-leading 3-year replacement warranty on key components.*

*A 3-year Supplemental Warranty covering pump assembly, frame, handle, lift linkage and pushrod weldments is included with all PTH50 models, excluding PTH50S/PS models.

Durability That Lasts

Crown takes the design of every truck seriously. The PTH 50 Series receives attention to performance and value in everything from engineering and design to manufacturing and testing.

Unlike some "throw-away" pallet trucks available today, Crown's PTH 50 Series features solid construction, generous use of steel, and ergonomic features that make it the easiest to use shift after shift, year after year. With millions of trucks sold worldwide, our reputation is an important part of each truck we sell.

**3
YEAR
WARRANTY***



Includes **sealed and lubricated for life** bushings and bearings where others feature grease fittings.

Feel the difference in Crown's **strong, yet ergonomic design** that uses more steel where it's needed most.

Refined Fork Tip Design **increases flexibility** for use in any application with a 2.95-inch fork clearance.

Steer and load wheels are engineered with **high-quality** compounds and bearings.

Forks with C-channel formed steel provide **added strength**.

Reinforced lower handle

**1M
CYCLES**

Pump valve tested to **over one million cycles** and minimizes contamination and corrosion with hard chrome pistons.

Cross braces and thick formed steel on lift linkage arms **resist twisting**.

Yellow chromate pins and shafts **resist corrosion**.

*A 3-year Supplemental Warranty covering pump assembly, frame, handle, lift linkage and pushrod weldments is included with all PTH 50 models, excluding PTH 50S/PS models.



Ease Of Use You Can Feel

Easy handling and versatile performance make the PTH 50 Series an ideal solution in every point of your operation. Crown designed the truck with features to provide greater convenience for the operator, so the truck works harder for you.

Repetitive Tasks Simplified

Complete recurrent tasks more easily and reduce fatigue with an ergonomic handle that includes:

- a contoured design
- low-stress pump action
- a neutral lever position that provides ergonomic access
- an automatic return-to-vertical position



Pallet entry/exit is **enhanced** with rollers, an exit ramp and a tapered fork tip design.

Box-style push rods contribute to **better longevity**.



Articulating wheels

The PTH 50 Series has 7-inch articulating wheels designed to maintain optimal contact with the floor to help maneuver over uneven surfaces, across docks, and in and out of trailers.

Easy to Maintain

Not only is the PTH 50 Series easy to handle and maneuver, Crown has designed it to be as maintenance-free as possible. Each part is economical to replace and readily available, so you can save effort, time and money.

Versatility That Gets the Job Done

The PTH 50 Series covers more than the basics—it is designed to be used in most any application, and offers excellent performance in numerous operations. Plus, there are several options available that you can use to customize your truck to meet the needs of your specific application and create even more possibilities for your facility.

Manual Scissor Lift

Forks are raised by simply pumping the handle with the lever in the "raise" position and lowered by pulling the lever to the "lower" position.



Powered Scissor Lift

Electrically-powered hydraulics raise the forks at the touch of a button.



Scissor Lift improves operator comfort and efficiency by avoiding unnecessary bending and lifting that can cause strains and stresses on the body. It has various uses as a hand pallet truck and a mobile work positioner, can handle skids and open-bottom containers, and can be used to hold materials that will be fed onto conveyors and printing or punch presses.



Load Backrest is constructed of 5/16-inch steel, and backrests are available in 48-inch and 60-inch sizes. Bolt-on installation simplifies field retrofits.



Skid Adapter increases lowered height to 5.5 inches to permit skid handling. Raised height increases to 10.5 inches. Adapter latches in vertical position for pallet-handling tasks.

Standard PTH

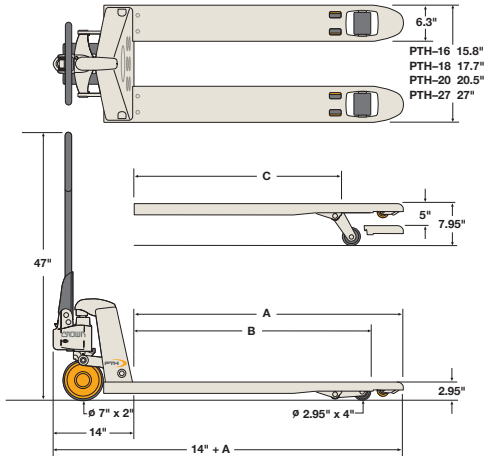

Model	Width (in.)	(A) Fork Length (in.)	(B) Load Wheel Lowered (in.)	(C) Load Wheel Raised (in.)	Weight (lb.)
PTH 50 16-36	15.8	35	29.5	23.5	132
PTH 50 18-42	17.7	42	35.5	29.5	141
PTH 50 18-48	17.7	48	41.5	35.5	148
PTH 50 20-36	20.5	36	29.5	23.5	137
PTH 50 20-42	20.5	42	35.5	29.5	143
PTH 50 20-48	20.5	48	41.5	35.5	150
PTH 50 27-36	27.0	36	29.5	23.5	143
PTH 50 27-42	27.0	42	35.5	29.5	150
PTH 50 27-48	27.0	48	41.5	35.5	159
PTH 50 27-54	27.0	54	47.5	41.5	174
PTH 50 27-60	27.0	60	53.5	47.5	187
PTH 50 27-72	27.0	72	65.5	59.5	209

Capacity	5000 lbs.	Polyurethane Wheels
Width of each fork	6.3"	Steer wheels
Lift	5"	Load wheels

Steer wheels \varnothing 7" x 2" wide
 Load wheels \varnothing 2.96" x 4" wide

Scissor Lift PTH

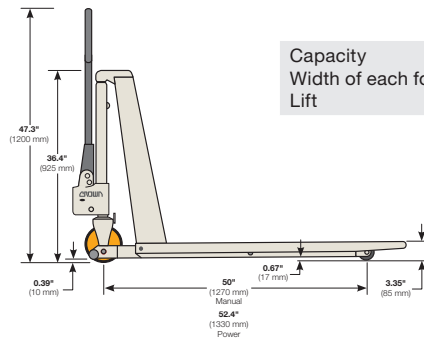
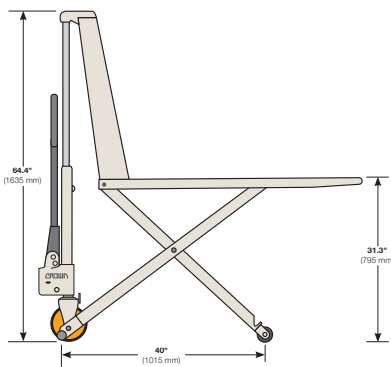

Model	Lift Type	Width (in.)	Fork Length (in.)	Overall Length (in.)	Fork Height Lowered (in.)	Weight (lb.)
PTH 50S 21-45	Manual	21.25	45.3	62.8	3.35	330
PTH 50S 27-45	Manual	27.00	45.3	62.8	3.35	348
PTH 50 PS 21-45	Electric	21.25	45.3	65.0	3.35	429
PTH 50 PS 27-45	Electric	27.00	45.3	65.0	3.35	445

Capacity	2200 lbs.	Polyurethane Wheels
Width of each fork	6.3"	Steer wheels
Lift	28"	Load wheels

Steer wheels \varnothing 7.1" x 2" wide
 Load wheels \varnothing 2.96" x 2.95" wide

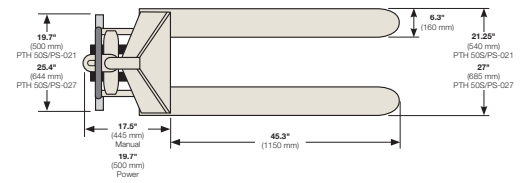

Wheel Options

The PTH50 Series is available with either polyurethane or nylon steer and load wheels. Both are non-marking but offer characteristics that may be better suited for certain environments. Nylon is a harder compound and provides a lower rolling resistance to allow for easier load maneuvering and reduced pull effort. Polyurethane offers more traction, specifically in wet environments. Polyurethane may also be preferred in noise sensitive areas.



Nylon



Polyurethane

Load Tray & Accessory Tube	Tray Width (in.)	Tray Length (in.)	Tray Height From Floor (in.)	Tray Capacity (lb.)
Fold Down Load Tray	27	21	44	50

Crown's Work Assist® Accessories Options



The Crown Work Assist System enables users to tailor truck features to the job. From phone holders (phone not included) to clipboards, Crown offers a full range of accessories.

The PTH 50 Series: Exceptional Long-Term Value.
 Contact your local Crown dealer or purchase online at crown.com



Crown Equipment Corporation

New Bremen, Ohio 45869 USA

Tel 419-629-2311

Fax 419-629-3796

crown.com

You can count on Crown to build lift trucks designed for safe operation, but that's only part of the safety equation. Crown encourages safe operating practices through ongoing operator training, safety-focused supervision, maintenance and a safe working environment. Go to crown.com and view our safety section to learn more.

Because Crown is continually improving its products, specifications are subject to change without notice.

Crown, the Crown logo, the color beige, the Momentum Mark, Work Assist and the ecologic logo are trademarks of Crown Equipment Corporation in the United States and other countries.

Copyright 2016-2020 Crown Equipment Corporation
SF14847 Rev. 05-20
Printed in U.S.A.



Clean Environment. Smart Business.

Printed on elemental chlorine free and sustainably forested paper.